

Auf der Gröb 2 c
83064 Raubling
Germany
Tel.: +49 (0)8035-9580448
Fax: +49 (0)8035-9580446
info@hernik.de • www.hernik.de

invoice / delivery address

Kom.:

Order

Offer

Rehab Car Seat **KIDSFLEX**



Exportprices **Release: 2023**

BASIC

	size 1	size 2	size 2XL
altura total	74 cm	80 cm	90 cm
crown height	67 cm	73 cm	82 cm
back height 	37 - 51 cm	41 - 57 cm	47 - 65 cm
seat width	31 cm	35 cm	40 cm
seat depth (adjustable)	28 - 33 cm	34 - 39 cm	40 - 46 cm
lateral support height (small)	26 - 36 cm	26 - 36 cm	34 - 44 cm
lateral support height (large)	30 - 40 cm	30 - 40 cm	38 - 48 cm
distance of lateral supports	16 - 28 cm	19 - 32 cm	24 - 37 cm
weight	8,2 kg	8,9 kg	12,3 kg
capacity	22 kg	36 kg	75 kg

common information (standard):

- seat depth adjustable
- headrest included (longer backrest)
- upholstery & cover
- backrest angle adjustable
- 5-point-harness with upholstery
- frame to fix a footrest, clamp bow or ISOFIX
- Crash tested according to ECE 44, ECE R16, ECE R14
- TÜV Product Service EN 12182 and DIN EN 1021



size 1
Black/Red
(300000-E1)

size 1
Black/Blue
(300000-E2)

1.675,00 €



size 2
Black/Red
(310000-E1)

size 2
Black/Blue
(310000-E2)

1.785,00 €



size 2XL
Black/Grey
(310000-E-XL)

2.150,00 €

Individual Dimensions - proceed to page 3 (310000-E-SB) 

Technische Änderungen und Druckfehler vorbehalten.





belt guide*:



- LEFT
- RIGHT



*please choose ONE of them

wider hip cushions (SW -4 cm)
(300850-E)
[€ 80,--]

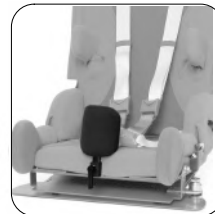

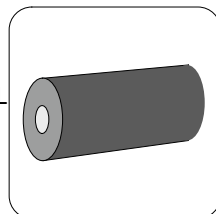
fittings for the different needs

<input type="checkbox"/> head support, soft (300050-E) [€ 190,-] 	<input type="checkbox"/> head support „Kick-Back“ with aluminum frame (300025-E) [€ 325,-] 	<input type="checkbox"/> head fixation (300630-E), [€ 265,-] NEW! 	leg support <input type="checkbox"/> left (300350-E) [€ 145,-] <input type="checkbox"/> right (300355-E) [€ 145,-] 
--	--	---	--

abduction block, removable <input type="checkbox"/> size 1 (300400-E) [€ 255,-] <input type="checkbox"/> size 2 (310400-E) [€ 265,-] <input type="checkbox"/> size 2XL (310400-E-XL) [€ 290,-] 	foot rest, height and angle adjustable <input type="checkbox"/> size 1 (300450-E) [€ 295,-] <input type="checkbox"/> size 2 und 2XL (310450-E) [€ 305,-] <input type="checkbox"/> swing up (300452-E) [€ 160,-] 	foot roll, height and angle adjustable <input type="checkbox"/> size 1 (300455-E) [€ 295,-] <input type="checkbox"/> size 2 und 2XL (310455-E) [€ 305,-] 
---	---	--

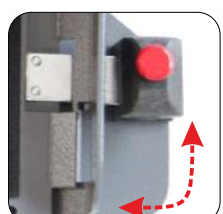

trunk supports, small (height: 11 cm, depth: 14 cm) <input type="checkbox"/> fix (300500-E) [€ 295,-] <input type="checkbox"/> swing away (300505-E) [€ 515,-] 	trunk supports, large (height: 21 cm, depth: 16 cm) <input type="checkbox"/> fix (300510-E) [€ 355,-] <input type="checkbox"/> swing away (300515-E) [€ 565,-] 	shoulder supports <input type="checkbox"/> (300700-E) [€ 355,-] 
--	---	--

fittings frame

swivel base <input type="checkbox"/> size 1, 2, 2XL (300200-E) [€ 395,-] <input type="radio"/> RIGHT <input type="radio"/> LEFT 	angular adjustment (0° - 10°) <input type="checkbox"/> size 1 (300100-E) [€ 195,-] <input type="checkbox"/> size 2 (310100-E) [€ 200,-] <input type="checkbox"/> size 2XL (310100-E-XL) [€ 255,-] 	extra angular adjustment (10° - 20°) <input type="checkbox"/> Gr. 1 (300105-E) [€ 260,-] <input type="checkbox"/> Gr. 2 (310105-E) [€ 275,-] <input type="checkbox"/> Gr. 2XL (310105-E-XL) [€ 310,-] 
--	---	--

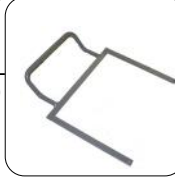
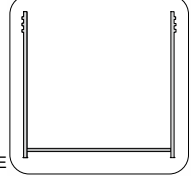

fastener (independent of the direction of rotation) <input type="radio"/> inside (standard) <input type="radio"/> outside (300220-E)	<input type="checkbox"/> Sandwich-Base (mounted under the base board) (300790-E), [€ 355,00] NEW! Useful in the following situations: - with very sporty shaped car seats, in order to compensate for the recess there. This results in a more stable position and more freedom of movement when using the swivel adapter. - with car Isofix brackets that are very far inside to allow nevertheless contact with the car's backrest and the IPAI-NXT (the ISOFIX adapter sits in the sandwich base) - approx. 1.5 kg additional weight
--	---

fittings for car installation

<p>ISOFIX adapter</p> <p><input type="checkbox"/> size 1 (300575-E) [€ 340,-]</p> <p><input type="checkbox"/> size 2 +2XL (310575-E) [€ 340,-]</p> 	<p>clamp bow (when there's no ISOFIX)</p> <p><input type="checkbox"/> size 1 (300550-E) [€ 170,-]</p> <p><input type="checkbox"/> size 2 +2XL (310550-E) [€ 170,-]</p> 	<p>outrigger*</p> <p><input type="checkbox"/> (310453-E), [€ 170,-]</p>  <p><small>*300450-E or 310450-E necessary!</small></p>	<p>additional belt guide (on the other side)</p> <p><input type="checkbox"/> (300075-E) [€ 135,-]</p> 
---	---	--	--

fittings security

<p>security tray</p> <p><input type="checkbox"/> size 1 (300600-E) [€ 450,-]</p> <p><input type="checkbox"/> size 2 (310600-E) [€ 465,-]</p> <p><input type="checkbox"/> size 2XL (310600-E-XL) [€ 490,-]</p> 	<p>security pad for the buckle with snap fastener</p> <p><input type="checkbox"/> size 1, 2, 2XL (300650-E) [€ 155,-]</p> <p>The buckle gets invisible for the child thanks to an additional pocket!</p> 	<p>NEW!</p> <p>security pad for the buckle with magnetic lock</p> <p><input type="checkbox"/> size 1, 2, 2XL (300655-E) [€ 195,-]</p> 
---	---	--

<p>protection mat (to protect the original seats of the car)</p> <p><input type="checkbox"/> (300780-E) [€ 80,-]</p> 	<p>individual colors for the cushions (300800-E), [€ 290,-]</p> <p>[one X means single-colored, two X means bicolored]</p> <table border="0"> <tr> <td></td> <td>inside</td> <td>outside</td> </tr> <tr> <td><input type="checkbox"/> red</td> <td><input type="checkbox"/></td> <td><input type="checkbox"/></td> </tr> <tr> <td><input type="checkbox"/> blue</td> <td><input type="checkbox"/></td> <td><input type="checkbox"/></td> </tr> <tr> <td><input type="checkbox"/> black</td> <td><input type="checkbox"/></td> <td><input type="checkbox"/></td> </tr> <tr> <td><input type="checkbox"/> grey</td> <td><input type="checkbox"/></td> <td><input type="checkbox"/></td> </tr> </table>		inside	outside	<input type="checkbox"/> red	<input type="checkbox"/>	<input type="checkbox"/>	<input type="checkbox"/> blue	<input type="checkbox"/>	<input type="checkbox"/>	<input type="checkbox"/> black	<input type="checkbox"/>	<input type="checkbox"/>	<input type="checkbox"/> grey	<input type="checkbox"/>	<input type="checkbox"/>	<p>belt to connect the chest straps (to improve the position of the belt in front of the breast)</p> <p><input type="checkbox"/> (300640-E) [€ 115,-]</p> 
	inside	outside															
<input type="checkbox"/> red	<input type="checkbox"/>	<input type="checkbox"/>															
<input type="checkbox"/> blue	<input type="checkbox"/>	<input type="checkbox"/>															
<input type="checkbox"/> black	<input type="checkbox"/>	<input type="checkbox"/>															
<input type="checkbox"/> grey	<input type="checkbox"/>	<input type="checkbox"/>															

individuality

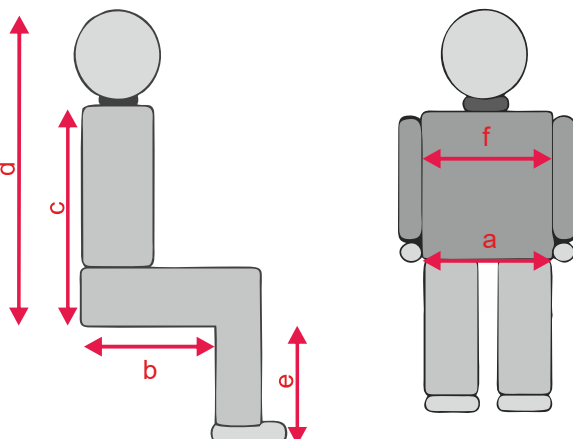
<p><input type="checkbox"/> Individual Dimensions (310000-E-SB), [€ 2.150,00 + Expense allowance]</p> <p>The expense allowance is always calculated individually depending on the desired measurements. Therefore ALWAYS request a quotation. (max. load: 75 kg; cover colour: grey-black)</p> 	<p><input type="checkbox"/> Patient dimensions:</p> <p>a (seat width): _____</p> <p>b (seat depth): _____</p> <p>c (back height): _____</p> <p>d (crown height): _____</p> <p>e (lower leg length): _____</p> <p>f (thorax width): _____</p> <p><input type="checkbox"/> Frame dimensions:</p> <p>a (seat width): _____</p> <p>b (seat depth): _____</p> <p>c (back height): _____</p> <p>d (crown height): _____</p>	<p><input type="checkbox"/> fabric, per running metre (300000-X), [€ 60,-]</p> <p><input type="checkbox"/> red (-B) _____ m</p> <p><input type="checkbox"/> blue (-D) _____ m</p> <p><input type="checkbox"/> black (-C) _____ m</p> <p><input type="checkbox"/> grey (-E) _____ m</p> <p><input type="checkbox"/> without cover (300000-OP), [- € PR]</p> <p><input type="checkbox"/> integration of a seat shell (300940-E)</p> <p><input type="checkbox"/> cover for a seat shell (300810-E)</p>
---	---	---